

# DR240

Technical parameters / Technické parametre	DR240/600	DR240/900	DR240/1300
Cutting chamber / Drviaca komora (mm)	600x620,5	600x900	600x1309
Width of knife / Šírka nástroja (mm)	36*	36*	36*
Hooks on the knife / Počet zubov na nástroji (pcs.)	5**	5**	5**
Number of knives / Počet nožov (pcs.)	17	25	36
Voltage / Elektrická sústava	400 V / 50 Hz	400 V / 50 Hz	400 V / 50 Hz
Protecting standard / Elektrické krytie	IP 54	IP 54	IP 54
Weight / Hmotnosť (kg)		4 500	
Varnish - machine / Povrchová úprava	RAL 7026 / RAL 3020	RAL 7026 / RAL 3020	RAL 7026 / RAL 3020
Gear boxes and motor / Pohony	NORD	NORD	NORD
Control unit / Riadiaca jednotka	SIEMENS	SIEMENS	SIEMENS
Monitoring relay contactors / Aktívne elektrické členy	SCHNEIDER	SCHNEIDER	SCHNEIDER
Electric box / Elektrická skriňa	RITTAL	RITTAL	RITTAL
Dimensions / Rozmery (mm)	A	620,5	1 309
	B	1 410,5	2 099
	C	1 920,5	2 210
	D	2 240,5	2 530
	E	2 940,5	3 230

\* Optional / Voliteľné: 18 mm, 36 mm, 72 mm

\*\* Optional / Voliteľné: 1-11 pcs. / ks:

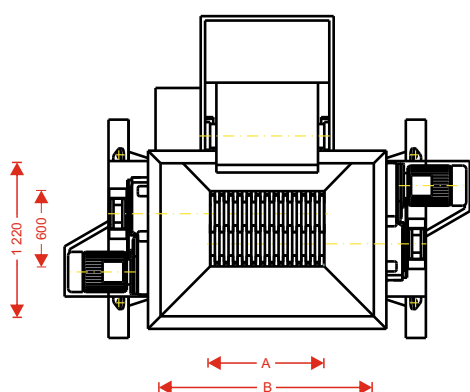
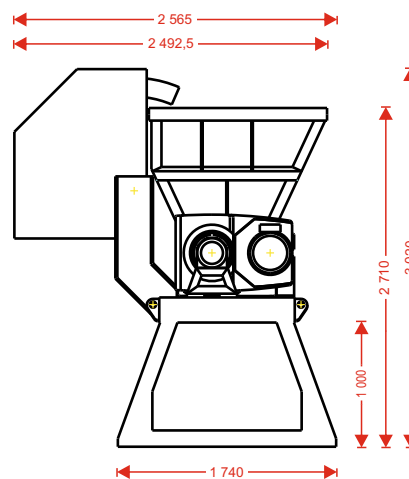
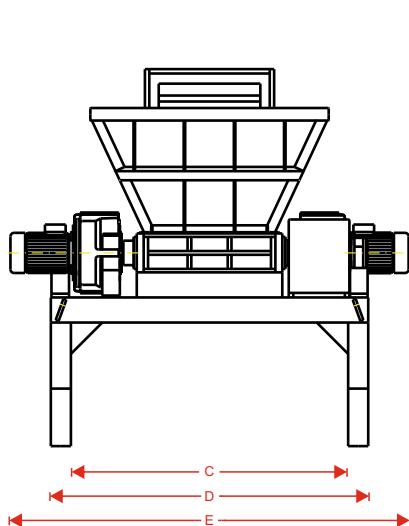

## VARIANTS OF ELECTRIC MOTORS / VARIANTY ELEKTROMOTOROV

Total input Celkový príkon	Rotor revolutions Otáčky rotorov	Max. torque Max. krútiaci moment	Shredding force Drviaca sila
24,2 kW	16/27	6,8 kNm	45 kN
26 kW	10/14	17 kNm	113 kN
37 kW	14/18	23,5 kNm	156 kN

ING. ČASTULÍK, Ltd., Ľubovníková 24, 841 07 Bratislava, Slovak Republic

ING. ČASTULÍK, s.r.o., Ľubovníková 24, 841 07 Bratislava, Slovenská republika

Phone / Tel.: ++421 915 054 958

E-mail: [castulik@castulik.sk](mailto:castulik@castulik.sk)